

FiberAlign® 90 and 130 Series

Direct-Drive, Multi-Axis Photonics Alignment System

- 3- to 6-axis photonics alignment
- Noncontact linear motor drive
- 2.5 nm resolution linear motion
- 0.027 to 0.058 arc-second angular resolution
- Turnkey drive and control electronics
- Direct-drive rotary axes
- Raster, spiral, or power peaking algorithms
- Interface to industry-standard power meters
- Integrated vision systems options



FA90 X-Y-Z volume is 729,000 mm³ (90 x 90 x 90 mm).

FA130 X-Y-Z volume is 2,197,000 mm³ (130 x 130 x 130 mm).

Introduction

Aerotech's FiberAlign® series is a high-performance photonics aligning system incorporating best-in-class drive and state-of-the-art axis control technology. Its modular design permits the selection of the number of axes, the distance to be travelled, and the amount of payload, all at high-speed, resolution, and accuracy.

Automated Production

As alignment accuracies, the quest for higher yields, and device volumes increase, the need for a precise, reliable, and repeatable motion system becomes increasingly important. Due to the rapidly changing nature of components and manufacturing processes, flexibility in system configuration becomes a must. Aerotech's FiberAlign series responds to and satisfies all of these requirements. More than thirty years of experience serving the high-technology OEM marketplace are reflected in these systems. With the selection of robust system components, high-volume production in a 24/7 manufacturing environment has become a reality.

Advanced Drive Technology

Only noncontact direct-drive technology offers the robust, accurate, high-speed and high-resolution positioning necessary for mass production of precision devices. Aerotech's state-of-the-art patent-pending drive technology offers industry leading resolution of 2.5 nanometers combined with high positioning speeds of greater than 250 mm/s. Utilizing ultra-quiet linear drives and advanced control technology, coupled with high-performance, best-in-class signal multipliers, Aerotech's FiberAlign series offers the best position repeatability, accuracy, and in-position stability to meet the motion system requirements of higher yields.

Fast Vision Alignment and Power Scanning Algorithms

A comprehensive software toolkit provides easy access to commonly used functions. Alignment functions such as hill climbing from a power meter input, and raster, square, or circular spiral scans, are easily implemented via standard functions. In addition to the automated tools, both joystick and on-screen jog control are available for manual operations.

FiberAlign 90 and 130 Series SPECIFICATIONS

FiberAlign 90 or 130

To satisfy the ongoing positioning and processing needs of the photonics manufacturing industry, Aerotech offers the FiberAlign 90 and 130 series. Both series' basic three-axis model can be extended with additional axes to satisfy the requirement to control motion in six axes: X, Y, Z, T (yaw), P (pitch), R (roll).

FiberAlign 90 represents the more compact version (1/3 the volume of FiberAlign 130) and is ideal where space is limited and travels need not exceed 25 millimeters in the primary axis. Due to its smaller size, the effective payload is also less than its larger version, the FiberAlign 130. By attaching the Universal Mounting Post to the Z axis, additional axes can be attached to provide high-resolution, high-accuracy rotary motion. This flexible arrangement permits the user to purchase only the number of axes needed to perform the task, yet allows further expansion if needed.

Yaw rotary motion is provided by Aerotech's ANT-20RA, a direct-drive, high-resolution rotary actuator, while pitch and roll motion are provided by Aerotech's advanced ANT-20G patent-pending, direct-drive, high-resolution goniometer. The rotary devices offer a 20 degree angular range with industry-leading resolution of up to 0.027 arc second.

The FiberAlign 130 is similar in construction to the 90 but offers a larger travel and larger load carrying capability in a slightly larger envelope. Travel for the X and Y axes are selectable up to 150 millimeters.

The FiberAlign 130 also accepts the ANT-20RA rotary actuator and the ANT-20G goniometers, providing six axes of motion control. Due to its larger size, the FiberAlign 130 also can accept the ADR-75 direct-drive rotary table that offers 360 degrees of continuous rotary motion.

Basic Model	FiberAlign 90	FiberAlign 130
Total Travel	50 mm x 50 mm x 25 mm	150 mm x 150 mm x 25 mm
Drive System	Linear Brushless Servomotor	
Feedback	Noncontact Linear Encoder	
Resolution	2.5 nm	
Maximum Travel Speed	100 - 250 mm/s	150 mm/s
Maximum Load ⁽¹⁾	5.0 kg	10.0 kg
Accuracy ⁽²⁾	±0.3 µm per axis ⁽²⁾ ; ±3 µm	
Bidirectional Repeatability	±100 nm	
Orthogonality	10 arc sec	5 arc sec
Material	Aluminum	
Finish	Black Anodize	

Notes:

1. Three-axis configuration.

2. Values with Aerotech controls and HAL options.



FA90 shown with the ANT-20G-50 goniometer.



FA130 shown with the ANT-20G-50 goniometer mounted using the Aerotech universal mounting post.

FiberAlign 90 and 130 Series DIMENSIONS

FiberAlign 90

All stages shown at center of travel.
 Mounting surface quality:
 Flatness 0.0002 in.
 Parallelism 0.0002 in.

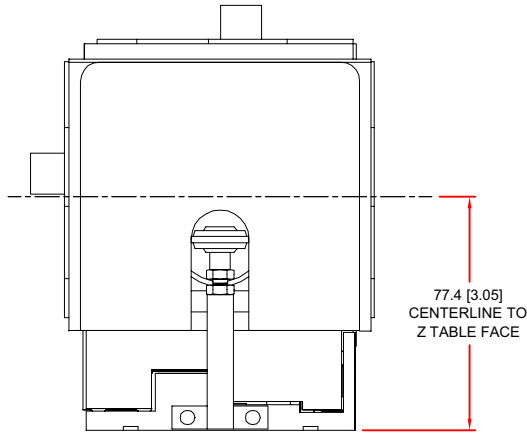

DIMENSIONS - MILLIMETERS [INCHES]

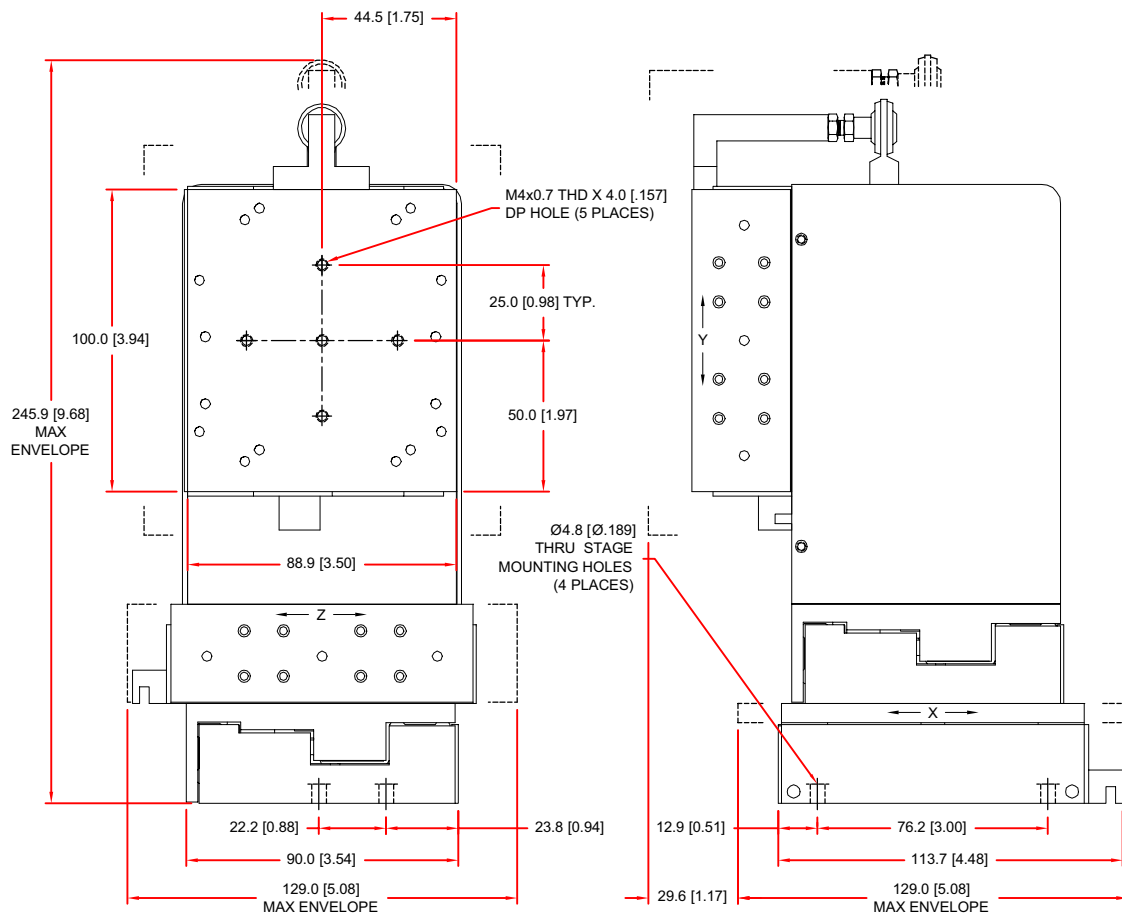

FiberAlign 90 and 130 Series DIMENSIONS

FiberAlign 130

All stages shown at center of travel.
 Mounting surface quality:
 Flatness 0.0002 in.
 Parallelism 0.0002 in.

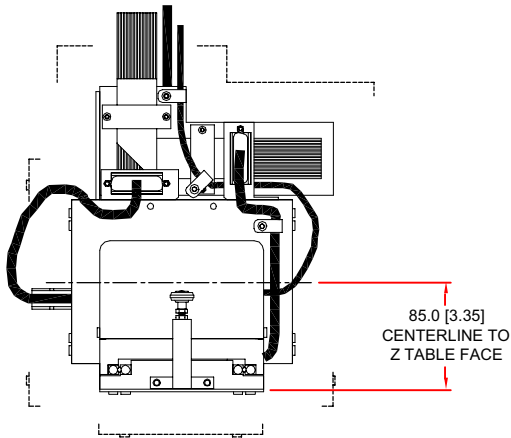

TRAVELS:
 X AXIS ALS130-050: 50mm
 Y AXIS ALS130-050: 50mm
 Z AXIS ALS130-025: 25mm

DIMENSIONS - MILLIMETERS [INCHES]

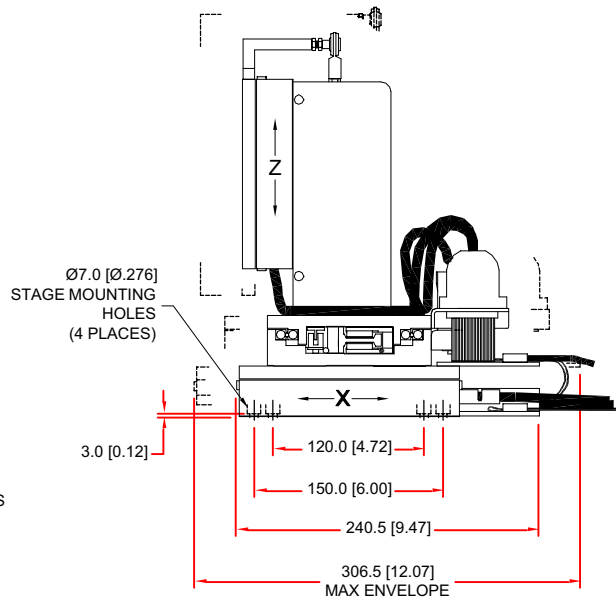
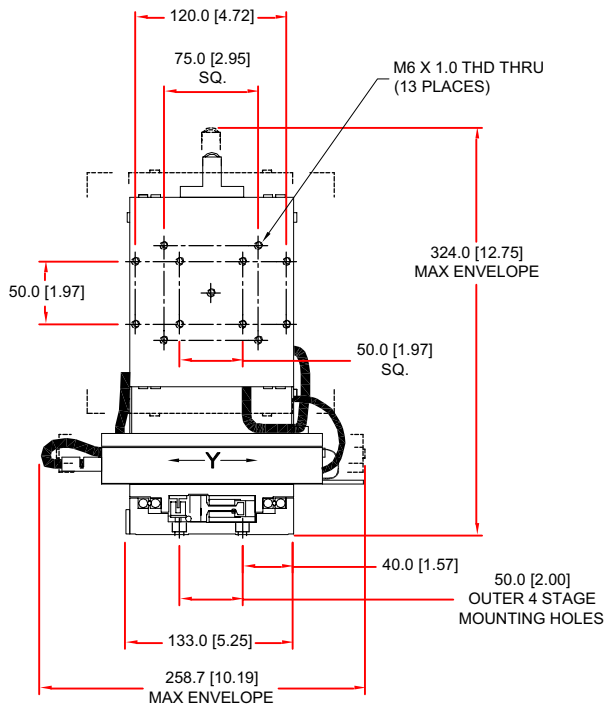

FiberAlign 90 and 130 Series ORDERING INFORMATION

Ordering Example

FA90	-25	-25	-25	-R	-AA
	Lower Axis Travel (mm)	Middle Axis Travel (mm)	Vertical Axis Travel (mm)	Opt Rotary Axis 1	Orientation
	-25	-25	-4	-T	-AA
	-50	-50	-25	-P	-AB
				-R	

FA90 Series Fiber Translator

FA90 Proprietary direct-drive motor technology, linear encoder based fiber translator. XYZ axes aligned to 10 arc sec orthogonal.

Note: Requires clean, dry air supply for pneumatic counterbalance when a vertical axis is specified.

Linear Stage Travel

-4	4 mm (.16 in) travel stage (vertical only)
-25	25 mm (1 in) travel stage (vertical or horizontal axis)
-50	50 mm (2 in) travel stage (horizontal only)

Optional Rotary Axes (Opt Rotary Axis 1-3)

For reference purposes the Z axis is considered to be the middle axis of a three-axis stack, X is the bottom axis, and Y is the vertical axis.

-T	Single “planar” rotary axis oriented as yaw, rotation about Y axis (ANT-20RA)
-P	Single “goniometer” rotary axis oriented as pitch, rotation about X axis (ANT-20G)
-R	Single “goniometer” rotary axis oriented as roll, rotation about Z axis (ANT-20G)

Note: For 5- and 6-axis configurations, please consult the factory.

Note: The above sequences represent the only valid rotary axis combinations.

Controller

-A3200	Automation 3200 software-only controller; Npaq® with MXR and DP32020E amplifiers, cables and software included
--------	--

See Motion Controllers section for specifications.

Orientation (-AA, -AB)

The letters in the orientation correspond to the standard X/Y/Z configurations detailed in Aerotech’s PA5 specification. The first letter indicates the orientation of the two horizontal axes and the second letter indicates the orientation of the vertical axes. These two combinations represent the only two standard configurations.

-AA	Bottom axis cable exits rear, middle axis cable exits left, vertical axis tabletop parallel to bottom axis facing to the right.
-AB	Bottom axis cable exits rear, middle axis cable exits left, vertical tabletop parallel to middle axis travel and facing the front.

FiberAlign 90 and 130 Series ORDERING INFORMATION

Ordering Example

FA130	-50	-50	-25	-T	-P	-R	-AA
	Lower Axis Travel (mm)	Middle Axis Travel (mm)	Vertical Axis Travel (mm)	Opt Rotary Axis 1	Opt Rotary Axis 2	Opt Rotary Axis 3	Orientation
	-25	-25	-25	-T	-P	-R	-AA
	-50	-50		-P	-R		-AB
	-100	-100		-R			-BA
	-150	-150					-BC

FiberAlign 130 Series Fiber Translator

FA130 Direct-drive linear motor, linear-encoder-based fiber translator. XYZ axes aligned to 5 arc sec orthogonal.

Note: Requires clean, dry air supply for pneumatic counterbalance for vertical axis.

Linear Stage Travel

-25	25 mm (1 in) travel stage (vertical axis only)
-50	50 mm (2 in) travel stage (horizontal axes only)
-100	100 mm (4 in) travel stage (horizontal axes only)
-150	150 mm (6 in) travel stage (horizontal axes only)

Optional Rotary Axes (Opt Rotary Axis 1-3)

For reference purposes the “Z” axis is considered to be the middle axis of a three-axis stack, X is the bottom axis, and Y is the vertical axis.

-T	Single “planar” rotary axis oriented as yaw, rotation about Y axis (ANT-20RA)
-P	Single “goniometer” rotary axis oriented as pitch, rotation about X axis (ANT-20G)
-R	Single “goniometer” rotary axis oriented as roll, rotation about Z axis (ANT-20G)
-T-P	Dual rotary axis, one planar and one goniometer (50 mm radius), yaw and pitch
-T-R	Dual rotary axis, one planar and one goniometer (50 mm radius), yaw and roll
-P-R	Dual rotary axis, two goniometers (50 mm and 90 mm), pitch and roll
-T-P-R	Triple rotary axis, one planar and two goniometers (50 mm and 90 mm), yaw, pitch, and roll

Note: The above sequences represent the only valid rotary axis combinations.

Controller

-A3200	Automation 3200 software-only controller; Npaq® with MXR and DP32020E amplifiers, cables and software included
--------	--

See Motion Controllers section for specifications.

Orientation (-AA, -AB, -BA, -BC)

The letters in the orientation correspond to the standard X/Y/Z configurations detailed in Aerotech’s PA5 specification. The first letter indicates the orientation of the two horizontal axes and the second letter indicates the orientation of the vertical axes. These four combinations represent the only four standard configurations. Combinations AA-BA, AB-BC can be considered as left- and right-hand orientations of the same stack, or mirror images of each other.

-AA	Bottom axis cable exits rear, middle axis cable exits left, vertical axis tabletop parallel to bottom axis facing to the right.
-AB	Bottom axis cable exits rear, middle axis cable exit left, vertical tabletop parallel to middle axis travel and facing the front.
-BA	Bottom axis cable exits rear, middle axis cable exits right, vertical axis tabletop parallel to bottom axis facing to the left.
-BC	Bottom axis cable exits rear, middle axis cable exits right, vertical tabletop parallel to middle axis travel and facing the front.