

AGS1000 Series

Linear Motor Gantries

Linear brushless servomotors for superior performance and longevity

Customizable Z and θ for increased flexibility

Optional machine base and risers

Optional electroless nickel for ESD protection and medical applications

Compact design reduces overall machine size

Ideal for die bonding, wire bonding, WLP, DNA profiling, and dispensing

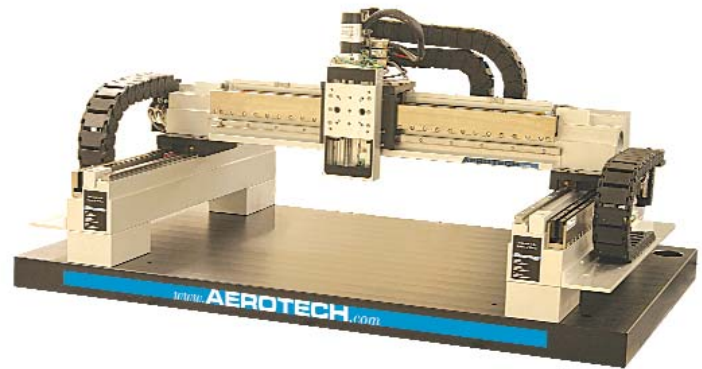

The AGS1000 series of Cartesian gantry systems puts Aerotech's core technologies and extensive manufacturing capability to work for you, providing outstanding performance and versatility in a wide range of automation platforms.

AGS1000 systems are designed for applications including high-speed pick-and-place, automated assembly, vision inspection, dispensing stations, and high-accuracy inspection. The AGS1000 is based on the industry leading AGS10000 gantry, and maintains many of the same leading-edge characteristics.

Linear Motor/Linear Encoder

Aerotech's high-performance BLMC series brushless linear servomotors drive the AGS1000 to speeds of 2 m/s and accelerations of 2 g. Feedback is from a rugged noncontact optical linear encoder. Resolution options range from 10 nm to 1.0 μm . Optimized to account for thermal expansion, the design ensures high accuracy under all operating conditions.

Rugged Design

Since the linear motor is a noncontact device, there is no backlash, wear, or maintenance. The bearings are preloaded linear motion guides with wiper seals and grease fittings and are mounted to provide optimized stiffness and load distribution. Standard lubrication is clean-room compatible.

Cable Management System

Extensive R&D has resulted in an optimized cable management system (CMS) that has been field proven to be the industry's most reliable design. Large bend radii and high-flex cables ensure that the AGS1000 provides millions of cycles of maintenance-free operation. In the unlikely event of a component failure, a modular design ensures that part replacement is fast and easy.

All customer cabling and pneumatics can be routed through the system e-chain. Connectors are provided at the workpiece and at the opposite end of the e-chain, greatly simplifying final machine integration.

Turnkey Operation

Aerotech's years of experience manufacturing precision positioning and control systems can be leveraged by acquiring a turnkey system. Typical options include Z-theta mechanisms, risers to accommodate automated parts handling equipment, and machine bases that are designed to accommodate the entire electronics subsystem.

Aerotech manufactures a wide range of high-performance amplifiers and advanced motion controllers that are optimized for high-performance automation applications.

AGS1000 Series SPECIFICATIONS

Basic Model		AGS1200-200	AGS1400-400	AGS1500-500
Total Travel ⁽¹⁾		200 mm x 200 mm	400 mm x 400 mm	500 mm x 500 mm
Drive System ⁽²⁾		Linear Brushless Servomotor — Dual BLMC-142 (bottom); Single BLMC-142 (top)		
Feedback		Noncontact Linear Encoder		
Resolution		10 nm - 1.0 μm (0.4 μin - 40 μin)		
Maximum Travel Speed ⁽³⁾		2 m/s (80 in/s)		
Maximum Linear Acceleration		2 g - 20 m/s ² (787 in/s ²) (no-load)		
Maximum Load ⁽⁴⁾		15 kg (33 lb)		
Continuous Force ^(2,5,6)	Lower Axis	Air Cooling (20 psi)	228 N (51.3 lb)	
		No Air	146 N (32.8 lb)	
	Upper Axis	Air Cooling (20 psi)	114 N (25.6 lb)	
		No Air	73 N (16.4)	
Peak Force ^(2,6)	Lower Axis	916 N (205.9 lb)		
	Upper Axis	458 N (103 lb)		
Accuracy ^(7,8)		±5.0 μm (±200 μin)		
Repeatability		±2.0 μm (±80 μin)		
Orthogonality		5 arc sec		
Nominal System Weight (Gantry only)		47.7 kg (105 lb)	65 kg (143 lb)	73.6 kg (162 lb)
Material		Aluminum		
Finish	Stage ⁽⁹⁾	Clear Anodize		
	Table	Hard Coat Anodize		

Notes:

1. Custom travel lengths available — contact factory.
2. Depends on configuration.
3. Maximum speed based on stage capability; maximum application velocity may be limited by system data rate and system resolution.
4. Maximum load based on bearing capability; maximum application load may be limited by acceleration requirements.
5. Thermal limitations of positioning stage with respect to performance may limit continuous force output.
6. Force may be limited by amplifier output.
7. Measured at center of travel.
8. Available with Aerotech controller.
9. Custom finishes available — contact factory.

AGS1000 Series DIMENSIONS

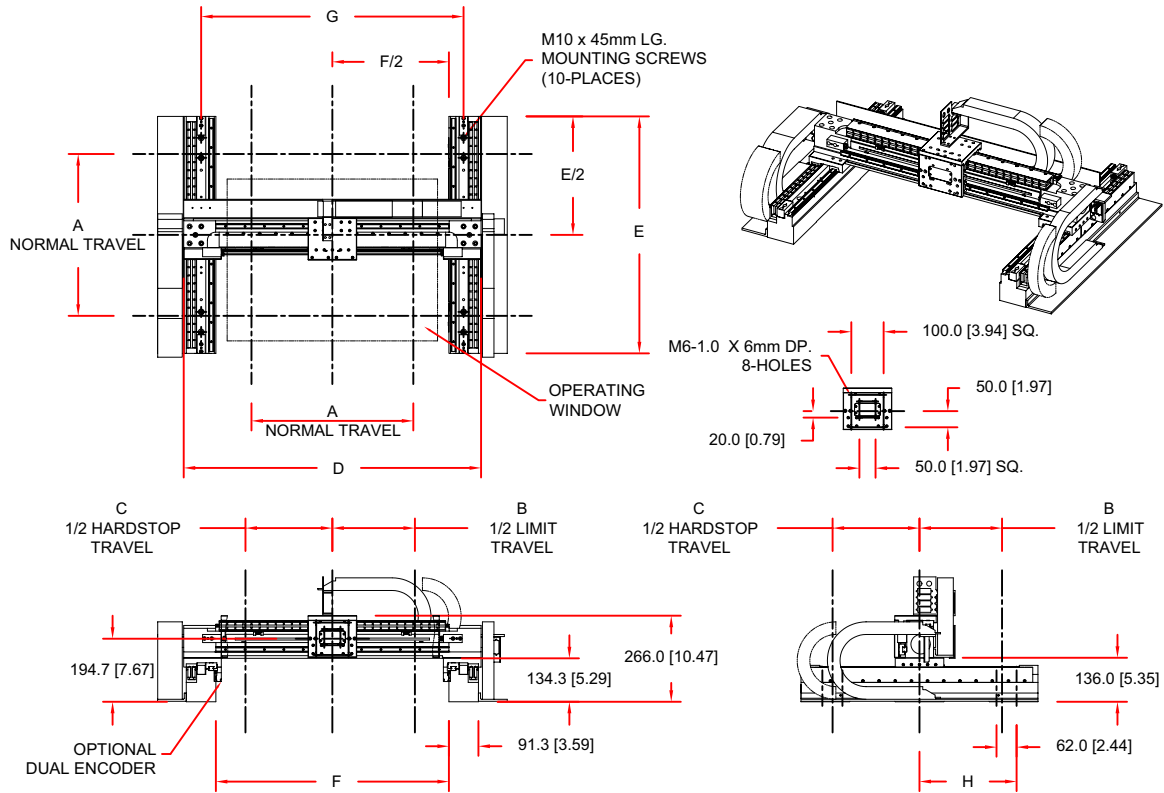

Basic Model	Dimensions - millimeters [inches]							
	A	B	C	D	E	F	G	H
AGS1200-200	200[7.87]	105[4.13]	110[4.33]	618.5[24.35]	432.0[17.00]	420.0[16.54]	510.5[20.10]	150[5.91]
AGS1300-300	300[11.81]	155[6.10]	160[6.29]	718.5[28.29]	532.0[20.94]	520.0[20.47]	610.5[24.04]	200[7.87]
AGS1400-400	400[15.75]	205[8.07]	210[8.27]	818.5[32.22]	632.0[24.88]	620.0[24.40]	710.5[27.97]	250[9.84]
AGS1500-500	500[19.68]	255[10.04]	260[10.24]	918.5[36.16]	732.0[28.82]	720.0[28.35]	810.5[31.91]	300[11.81]

AGS1000 Series ORDERING INFORMATION

Ordering Information

AGS1	200	-200	-10X2	-10	-LT50X5	-LT50X5	-BP
Series	X-Travel (mm) (Lower Axis)	Y-Travel (mm) (Upper Axis)	X-Motor (Lower Axis)	Y-Motor (Upper Axis)	X-Encoder (Lower Axis)	Y-Encoder (Upper Axis)	Base Plate
	-200-200	-200-200	-10X2	-10	-LTxxAS	-LTxxAS	-BPR
	-400-400	-400-400			-LTxxX5	-LTxxX5	
	-500-500	-500-500			-2LTxxAS		
					-2LTxxX5		

AGS1000 Series Linear Motor Gantry

AGS1200-200	200 mm x 200 mm (8 in x 8 in) cartesian gantry with linear motor, linear encoder, and limits
AGS1400-400	400 mm x 400 mm (16 in x 16 in) cartesian gantry with linear motor, linear encoder, and limits
AGS1500-500	500 mm x 500 mm (20 in x 20 in) cartesian gantry with linear motor, linear encoder, and limits

Motor

-10X2	Dual brushless linear motors — dual BLMC-142 (lower X-axis only)
-10	Brushless linear motor — BLMC-142 (upper Y-axis)

Limits

-NC	Normally closed end of travel limit switches (standard)
-NO	Normally open end of travel limit switches

Standard Linear Encoders

-LT20AS	Linear encoder for AGS1200-200; amplified sine output
-LT20X5	Linear encoder for AGS1200-200; 1.0 micron line driver output
-LT40AS	Linear encoder for AGS1400-400; amplified sine output
-LT40X5	Linear encoder for AGS1400-400; 1.0 micron line driver output
-LT50AS	Linear encoder for AGS1500-500; amplified sine output
-LT50X5	Linear encoder for AGS1500-500; 1.0 micron line driver output
-2LT20AS	Dual linear encoder for AGS1200-200; amplified sine output; (lower X-axis only)
-2LT20X5	Dual linear encoder for AGS1200-200; 1.0 micron line driver output; (lower X-axis only)
-2LT40AS	Dual linear encoder for AGS1400-400; amplified sine output; (lower X-axis only)
-2LT40X5	Dual linear encoder for AGS1400-400; 1.0 micron line driver output; (lower X-axis only)
-2LT50AS	Dual linear encoder for AGS1500-500; amplified sine output; (lower X-axis only)
-2LT50X5	Dual linear encoder for AGS1500-500; 1.0 micron line driver output; (lower X-axis only)

Base Plate

-BP200-200	Aluminum baseplate for AGS1200-200
-BP400-400	Aluminum baseplate for AGS1400-400
-BP500-500	Aluminum baseplate for AGS1500-500
-BPR200-200	Aluminum baseplate for AGS1200-200 with 150 mm (6 in) risers
-BPR400-400	Aluminum baseplate for AGS1400-400 with 150 mm (6 in) risers
-BPR500-500	Aluminum baseplate for AGS1500-500 with 150 mm (6 in) risers

Accessories (to be ordered as separate line item)

Z	100 mm (4 in) travel z-stage
THETA	360° travel theta axis
MB200-200	Steel weldment machine base for AGS1200-200
MB400-400	Steel weldment machine base for AGS1400-400
MB500-500	Steel weldment machine base for AGS1500-500